

017: 1998

CEB  
STANDARD

---

## RING MAIN UNIT

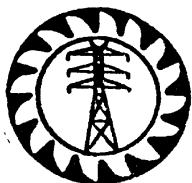

CEYLON ELECTRICITY BOARD  
SRI LANKA

---

## CONTENTS

	<b>PAGE</b>
1. Scope	2
2. System Parameters	2
3. Service Conditions	2
4. Applicable Standards	3
5. Basic Features	4
6. Quality Assurance	11
7. Additional Requirements	11
8. Information to be Furnished with the Offer	13
9. Technical Literature & Drawings	14
10. Inspection & Testing	14
11. Annex	15

## SPECIFICATION FOR RING MAIN UNIT

### 1.0 SCOPE

This specification covers the design, manufacture and testing of Ring Main Units for a 11kV cable network system.

### 2.0 SYSTEM PARAMETERS

(a)	Nominal Voltage	-	11 kV
(b)	System highest voltage	-	12 kV
(c)	System frequency	-	50 Hz.
(d)	Number of phases	-	03
(e)	Method of earthing	-	Through a resistance of 4.75 ohms
(f)	Short time withstand current (for 1s)	-	20 kA rms.

### 3.0 SERVICE CONDITIONS

(a)	Annual average ambient temperature	-	30°C
(b)	Maximum ambient temperature	-	40°C
(c)	Temperature rise due to solar absorption of 1200 W/M <sup>2</sup>	-	10°C
(d)	Maximum relative humidity	-	90%
(e)	Environmental conditions	-	Humid tropical climate with heavily polluted atmosphere.
(f)	Operational altitude	-	From M.S.L. to 1000M above M.S.L.
(g)	Insulation level		
	(i) Impulse withstand voltage (1.2kV/50 μs) peak	-	75 kV.
	ii) Power frequency withstand voltage (1min.)	-	28 kV.

**4.0 APPLICABLE STANDARD:**

The equipment and the components supplied shall be in accordance with the standards specified below or later editions and/or amendments thereof.

- |    |  |   |   |
|----|--|---|---|
| a) | BS 5463 (1991)                               | - | H.V. Switches for rated voltages above 1 Kv   |
| b) | BS 159 (1992)                                | - | Busbar and Busbar connections   |
| c) | BS EN 60282-1(1993)<br>IEC 282 Part 1 (1994) | - | Current limiting<br>Fuses   |
| d) | IEC 420 (1990)                               | - | High Voltage alternating current<br>Switch-Fuse combinations                                |
| e) | BS EN 60129 (1994)                           | - | A.C. Disconnecters (Isolators)<br>and Earthing Switches                                     |
| f) | BS 6867 (1987)                               | - | Code of practice for<br>Maintenance of Switchgear   |
| g) | BS 775 Part 2 (1984)                         | - | A.C. Contactors for voltages<br>above 1 kV and up to including<br>12 kV                     |
| h) | BS 223 (1985)                                | - | High Voltage Bushings   |
| i) | BS 2757 (1986)                               | - | Thermal classification of<br>electrical insulation.   |
| j) | BS 5493 (1977)                               | - | Code of practice of protective<br>coating of item and steel<br>structures against corrosion |
| k) | BS EN 22063 (1994)                           | - | Metallic and other inorganic<br>coatings.   |
| l) | IEC 71-1 (1993) &<br>71-2 (1976)             | - | Insulation Coordination   |
| m) | IEC 298 (1990)                               | - | A.C. metal enclosed<br>BS5227 (1992)<br>switchgear and control gear                         |

- |    |                      |   |  |
|----|----------------------|---|--|
| n) | IEC 529 (1989)       | - | Degrees of Protection provided by enclosures   |
| o) | BS 148 (1984,1992)   | - | Insulating oil for transformers and switchgear |
| p) | BS 5207 & 509 (1975) | - | Sulphur hexafluoride for electrical equipments |
| q) | BS 6134 (1991)       | - | Pressure and vacuum switches.                  |

The equipment and component conforming to any other international standards which are equal to or higher but not less rigid than the standards and specification stipulated could be offered.

When such alternative standards are used reference to such standards shall be quoted and English Language copies of such standards shall be furnished with the offer.

## 5.0 BASIC FEATURES

### 5.1 Design

The Ring Main Unit (RMU) shall be designed to operate at the rated voltage (System highest voltage) of 12 kV and shall consist of two numbers of ring main switches and one number Tee-off fuse switch for control of 11 kV/L.T. transformers up to 1000 kVA.

The RMU shall be of the types and operational category as specified in the Schedule of Technical Requirements stipulated in Clause 5.6.

### 5.2 Basic constructional Aspects

- (i) The equipment offered shall be metal enclosed free standing or transformer mounted type as requested in the schedule of prices.
- (ii) The free standing RMU shall be stable and rigid on its own support.
- (iii) The unit shall be provided with lifting facilities of proven design for easy handling.
- (iv) The equipment shall be complete with necessary cable termination boxes, earth fault indicating device with current transformers, fuses switch and switching equipments with necessary safety interlocks and designed for minimum maintenance.
- (v) The mechanical design and strength of the unit and components shall be able to bear the mechanical stresses on the switch terminals when installed and in operation.

- (vi) The equipment shall withstand the electro -dynamic forces without reduction of the switches reliability or current carrying capacity.

### 5.2.1 Cable Terminations

- (i) The Ring Cable terminations shall be provided on the sides of the RMU. The T-off termination shall be provided on it's rear in the case of free standing type. In the case of transformer mounted type, T-off connection shall be brought out in such a manner to connect direct to the transformer HT side.
- (ii) The cable terminations shall be suitable to receive three core underground cable of sizes up to 240mm<sup>2</sup>.

### 5.2.2 Operational Switches:

- (a) R.M. Switches - Shall be a bank of three positions (viz. ON, OFF, EARTH OFF/ON) single break type suitable for the three phase current carrying capacity as specified.
- (b) Tee-off Switch - Shall be a bank of three positions (viz. ON, OFF, EARTH OFF/ON) double break type suitable for the three phase current carrying capacity as specified. It shall incorporate High Voltage current limiting fuses and the fuses to have the Characteristics as specified in Clause 5.6.4.
- (c) Current Limiting - Shall be of the striker pin type and also Fuse Links capable to actuate a common tripping bar to avoid chances of single phasing.

### 5.2.3 Earth Fault Indicators

- (i) Earth Fault Indicating Device shall be provided for each incoming cables to indicate the faulty section during earth fault.
- (ii) The Earth Fault Indicating Device shall comprise of an earth fault relay Indicator which shall directly be operated by the secondary current from the split-core type core-balance transformer. After re-energising the indicator should be automatically re-set by single phase 230 V a.c. supply.

- (iii) The split-core type core-balance transformer shall be fixed to the cable termination box as indicated in the Drawing No. DS&S/017-2:1996.

The split-core type current transformer shall have a transformation ratio of 60:1, Accuracy Class 5 and burden 1.5 VA, conforming to BS 3938. The pickup value of the earth fault indicating device shall not be less than 25 Amp primary current and the drop out value shall not be more than 40 Amp primary current.

- (iv) The device shall be sensitive to low magnitude earth fault current

#### **5.2.4 Operational Positions and Instructions**

- (i) All operational instructions, earth fault indicators / positions shall be at the front of the unit protected by weatherproof hinged lockable doors.
- (ii) Lockable storage facilities shall be provided for removable operating handles in a position readily accessible from the front of the equipment.
- (iii) Operating handles shall be considered as a part of the unit and shall be provided with each R.M.U.

#### **5.2.5 Fuse Link Replacement**

- (i) Fuse links shall be provided on a removable carriage and the opening of the fuse chamber access cover shall dis-connect the carriage in order to provide double disconnection.
- (ii) Latching arrangements of fuse carriage, after partly lifting for full access of fuses, shall be provided.
- (iii) The fuses shall be in accordance to Schedule of Technical Requirements.

#### **5.2.6 Contactors and Conductors**

All conductors and contacts shall be of high quality copper as per the stipulated standard and all making/breaking contacts shall be silver plated.

### 5.2.7 Anti-corrosive Prevention

- (i) The chamber interiors shall be cleaned of all scaled rust by shot blasting or any other approved chemical method and shall be coated with paint/enamel or suitable medium resistive to the electrical insulating medium adopted.
- (ii) The exterior of the unit cleaned of all scale and rust by shot blasting or any other approved chemical method and shall be treated with zinc spray.
- (iii) Every precautionary method should be taken to design and construct the unit for weatherproof against the service conditions indicated.

### 5.2.8 Foundations

The floor fixing of the equipment shall allow for mounting on a simple rectangular plinth with a flat surface.

### 5.3 Basic Operational Aspects

- (i) The operating mechanisms shall be integral with switches, interlocks etc. and be of independent manual type.
- (ii) The operating mechanisms shall be of independent manual type and shall be integral with switches and interlocks.
- (iii) The movement of any operating handle against an interlock shall not by any means originate, store or activate the energy mechanism.
- (iv) In addition to the operating handle arrangements, means shall be provided at the T-off switch for manual tripping from: "ON" to "OFF" positions incorporating locking facilities.

#### 5.3.1 Operational Interlocks:

Safety of operation shall be ensured by interlocks which prevent -

- (a) Inadvertent operation of any R.M. switch & T-off switch direct from the "ON" position to "EARTH-ON" position or vice versa.
- (b) Opening and closing of any access cover or doors of the switches and fuse chamber unless the associated switch is at the "EARTH-ON" position, mechanisms reset and operational rod removed.



- (c) Access of fuse removal unless the fuses are doubly isolated and earthed.
- (d) Test plugs or probes being inserted or withdrawn unless the relevant switch is at the "EARTH-ON" position.
- (e) Operation of any switch to "ON" position from any position with the access cover opened.
- (f) Operation of any switch from "EARTH-ON" to "OFF" position unless the associated access cover is closed and bolted or test plugs inserted.
- (g) Reclosers of fuse chamber access with a blown fuse in circuit, a fuse holder/carriage not latched in, a fuse holder trip lever incorrectly set.
- (h) Operation of fuse switch from "OFF" to "ON" position with conditions referred in sub-clause (g) above, fuses isolated and earthed, and/or fuse access and switch access covers not fully bolted down.
- (i) In case of more than one handle operating shafts, simultaneous dual operation, ensuring access only to one of the two operating shafts.

### **5.3.2 Padlocking Arrangements**

Arrangements shall be provided for locking up with padlocks of size 1" for each of the following:

- (a) Each of the access doors and covers.
- (b) Each of the operating handle to the frame work.
- (c) Each control position to prevent moving from "OFF" position to the "ON" position and vice versa.
- (d) Each control position to prevent moving from "OFF" position to the "EARTH-ON" position and vice versa.

### **5.3.3 Testing Facilities**

- (i) Facilities to carry out H.V. tests on R.M. feeders connected to the ring main switches shall be provided.

- (ii) These facilities need not be provided for the T-off switch. Adequate numbers of testing devices as specified in the sub-clause 6.1 (c) shall be supplied along with the units.

#### 5.4 Earthing

- (i) All panel and access covers or doors etc. rotating about hinges shall be earthed to the adjacent main frames by copper flexible protective bonding conductors.
- (ii) The frame of each switch shall be provided with reliable earthing terminal having a clamping screw of not less than 12 mm in diameter.
- (iii) All the earthing terminals shall be inter-bonded for equal potential and brought to main earthing terminals.
- (iv) The earthing conductor or strap mainly of copper shall be mechanically protected as well as against corrosion and be of adequate size for the coordinated ratings as per schedule of particulars.

#### 5.5 Insulating Medium:

- (i) The units shall be supplied with the complete insulating medium. The recommended insulating medium for switch chambers is oil. However, equipment with any other approved insulating medium offered and supported with full technical particulars could be considered.
- (ii) Relevant gauge indicators and Sample testing facilities should be provided if the medium is oil.
- (iii) Design and application of the insulating medium in the unit shall be in strict compliance to the relevant standard specification specified.

#### 5.6 Schedule of Technical Requirements

The RMU shall conform to the following Technical Requirements.

1. Type : (Clause 4.0) Outdoor - non extensible
2. Category : (Clause 4.0) Standard Operation

3. Cable Size : Upto 240mm<sup>2</sup> 3 core PILCSWA/XLPE Copper Cables complying with B.S. 6480 Part 1 (1969)/B.S. 6622 (1985)
4. Fuses : Oil immersed.
  - (a) Type : Type II
  - (b) Size : 256 mm. length x 63.5 mm diameter at ends x 67 mm.diameter barrel.
  - (c) Fuse rating : 30 Amps, 50 Amps and 75 Amps.
5. Cable End Box: Shall be suitable to receive both heat shrinkable type termination and compound filled type termination.
6. Accessories : Sub clause 6.1 (a) to (d) to be supplied.
7. Operational Switches Characteristics:

## **6.0 QUALITY ASSURANCE**

Quality Assurance System conforming to ISO 9001 shall be followed in the manufacture of Ring Main Unit and the manufacturer shall furnish ISO 9001 Quality Assurance Certification Document with the offer.

## **7.0 ADDITIONAL REQUIREMENTS**

### **7.1 Accessories**

The following accessories shall be incorporated with the offer and supplied along with the RMU.

- (a) Foundation grouting bolts of correct size and numbers in 10% excess.
- (b) Cable end boxes complete with brass cable wiping glands.
- (c) Testing equipments to facilitate testing referred in sub clause 5.3.3 at the rate of one number per ten or part thereof the RMU supplied.
- (d) Any other accessories as per schedule of prices.

List of recommended accessories with individual prices of each accessory concerned shall be furnished with the offer. The recommendation shall be for a period of five years.

### **7.2 Tools**

Any form of special tools or devices necessary for routine operation and maintenance of the unit shall be incorporated and supplied with the unit. If such tools are supplied and employed a list of such tools along with the detailed prices shall be furnished with the offer. The recommendation of the tools shall be for a period of five years operation.

### **7.3 Spares**

- i) Spares as specified in the schedule of prices shall be incorporated in the offer and supplied with the units.
- ii) The quantity of each size of fuses shall be as indicated in schedule of prices.

- iii) A list of recommended spare parts along with the detailed prices for five years trouble free operation shall be furnished with the offer.

#### **7.4 Rating Plate markings**

Rating plate shall provide the data of the switches and be weather-proof and corrosion-proof. The plate shall be positioned in the front of the unit and be clearly visible from the normal operating location of the device.

Information to appear on the name plate are -

- (a) Number and year of the standard adapted.
- (b) Manufacturer's identification (Name, country of manufacture etc.)
- (c) Designation of type.
- (d) Class and category.
- (e) Serial number and year of manufacture.
- (f) Rated voltage and frequency.
- (g) Class of insulation.
- (h) Rated pressure of compressed gas (or vacuum) for operation, if applicable.
- (i) Rated pressure of compressed gas (or vacuum) for interruption, if applicable.
- (j) Weight of equipment without insulating medium and cable terminations.
- (k) Weight and volume of insulating medium.
- (l) Characteristic of switches.

## **7.5 Packing**

The equipment shall be packed in a suitable manner for shipment to prevent damage during shipment and road transport up to Purchaser's warehouse.

- i) The fuses for the T-off fuse switch shall be installed before packing the equipment.
- ii) The cable end boxes shall also be packed with the RMU.
- iii) The spare fuses shall be packed separately to withstand rough handling.

## **8.0 INFORMATION TO BE SUPPLIED WITH THE OFFER**

8.1 The following shall be furnished with the offer.

- (a) Catalogues describing the equipment and indicating the model.
- (b) Literature describing the operational feature of the equipment.
- (c) Rated values and characteristics of all switches, busbars, fuses, insulating medium etc.
- (d) Constructional features, materials used for components and relevant technical literature and dimensioned drawings.
- (e) Operating mechanism of the switches and associated equipment/ interlocks/access covers and doors including sequence of operation.
- (f) Mechanical characteristic incorporating overall dimensions in open and closed positions, weight with and without insulating medium, foundation layout dimensions, weather shield particulars, anticorrosive preventive measures, padlocking arrangements.
- (g) Drawing of name plate to scale incorporating the particulars called for.
- (h) Details of earthing, earth conductor/strap bonding and termination.

- (i) Certificate of type tests for the following carried out in accordance to the specified standard.
  - i) Dielectric Tests
  - ii) Temperature - rise Tests
  - iii) Making and Breaking Tests
  - iv) Short-Circuit Current carrying capability
  - v) Operation and Mechanical endurance
- (j) ISO 9001 Certification.

**8.2** Test certificates, performance curves etc. furnished shall be based on the type tests confirming to the relevant British Standard. The tests certificates should clearly identify the equipments concerned, showing the Manufacturer's identity, type number and basic technical parameters.

The test certificates referred to shall be issued from an **internationally recognized independent testing authority**.

**8.3** Failure to furnish the particulars requested in Clause 8.1 will result in the offer being rejected.

## **9.0 TECHNICAL LITERATURE & DRAWINGS**

The selected tenderer along with the equipment should supply relevant drawings, technical literatures, hand-books etc. in order to facilitate installation, operation and maintenance.

## **10.0 INSPECTION AND TESTING**

### **10.1 Inspection**

The selected Bidder shall make necessary arrangements for inspection by a Representative of the Purchaser and also to carry out in his presence necessary Routine or Sample Tests of the materials, equipment offered.

### **10.2 Testing (routine / Sample)**

Routine or Sample Tests Conforming to the relevant standard shall be carried out and following sample test shall be witnessed by the Purchaser's Representative.

- (i) Dielectric withstand tests
- (ii) Mechanical operation (including interlocks) checks.
- (iii) Leakage test.
- (iv) Power frequency voltage withstand tests
- (v) Measurement of resistance

### 10.3 Routine / Sample Test Certificates

These Test certificates will form a part of the shipping documents. Extra copies of these test certificates shall also be supplied with the equipment.

### 11.0 ANNEXURES:

- i) Annexure A - 1 - Drawing No. DS&S/017-1: 1996  
- Schematic diagram
- ii) Annexure A – 2 - Drawing No. DS&S/017-2: 1996  
- Application of Earth Fault Indicators  
on Ring Main Cable System
- iii) Annexure A - 3 - Schedule of Particulars





Amendment Slip No. 02  
Effective from 07<sup>th</sup> April 2005  
To CEB Standard 017: 1998

Specification for Ring Main Unit

REVISED TEXT

---

April 2005

**THE PROPOSED AMENDMENT TO CEB STANDARD 017: 1998  
SPECIFICATION FOR RING MAIN UNITS**

5.0 Basic Features

5.1 Design

To add the following to the 3<sup>rd</sup> para

***“RMU should have the provision to install actuator assemblies for upgrading the RMU for future Automation & remote control facilities to integrate the propose SCADA system for the Colombo City 11kV network..***

***Tenderer shall provide information regarding the possibilities of installing actuator assemblies to their RMUU and their experience in providing remote control facilities to RMUU.***

***Ring Main Unit models which have no facility for upgrading to automation & remote control functions will be liable for rejection.”***

**ANNEXURE A- 3****SCHEDULE OF PARTICULARS**

Bidders are requested to furnish the following particulars of the RMU offered

- (a) Number and year of the standard adapted. :
- (b) Country of manufacture. :
- (c) Designation of type. :
- (d) Class and category. :
- (e) Serial number and year of manufacture. :
- (f) Rated voltage and frequency. V/Hz :
- (g) Class of insulation. :
- (h) Characteristic of switches. :
- (i) Rated normal current
- |    |                 |   |       |
|----|-----------------|---|-------|
| a. | Busbars         | A | :     |
| b. | R.M. Switches   | A | : 400 |
| c. | T. off Switches | A | : 200 |
- (j) Rated lightning impulse withstand voltage (1.2kV/50 $\mu$ s) peak
- |    |                 |    |      |
|----|-----------------|----|------|
| a. | Busbars         | kV | :    |
| b. | R.M. Switches   | kV | : 75 |
| c. | T. off Switches | kV | : 75 |
- (k) Rated one minute power frequency withstand voltage
- |    |                 |    |      |
|----|-----------------|----|------|
| a. | Busbars         | kV | :    |
| b. | R.M. Switches   | kV | : 28 |
| c. | T. off Switches | kV | : 28 |
- (l) Rated short time current and duration.
- |    |                 |          |
|----|-----------------|----------|
| a. | Busbars         | kA/sec.: |
| b. | R.M. Switches   | kA/sec.: |
| c. | T. off Switches | kA/sec.: |
- 20 kA/1 Sec.

- (m) Rated breaking capacity
  - a. R.M. Switches A : 400
  - b. T. off Switches kA : 20 rms.
  
- (n) Rated short circuit making capacity
  - a. R.M. Switches kA : 46
  - b. T. off Switches kA : 46
  
- (o) Weight of equipment without insulating medium and cable terminations. kg :
  
- (p) Weight and volume of insulating medium. kg :
  
- (q) Type and size of Cable terminations. :
  
- (r) Any deviation from this specification if so indicate the relevant clause Nos. :
  
- (s) Whether the equipment is independent manual operating
  
- (t) Whether Type Test Certificates furnished.
  
- (u) Whether ISO 9001 certificate furnished

---

Seal and Signature of the Manufacturer/Bidder

### For PILC Cable

①

Oil Switch Fitted with Insulated Gland and External Core Balance C.T. Clamped on PILC Cable

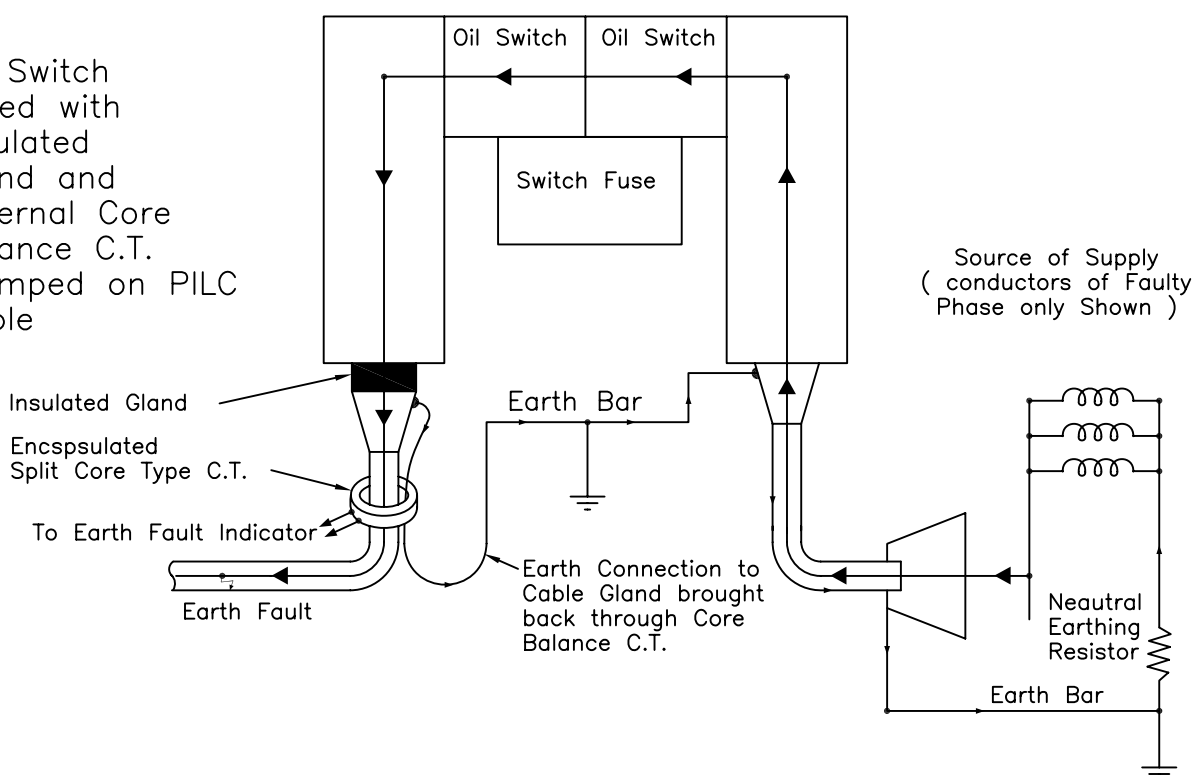

### For XLPE Cable

②

Core Balance C.T. mounted inside Cable Box of oil Switch around Phase Conductors only

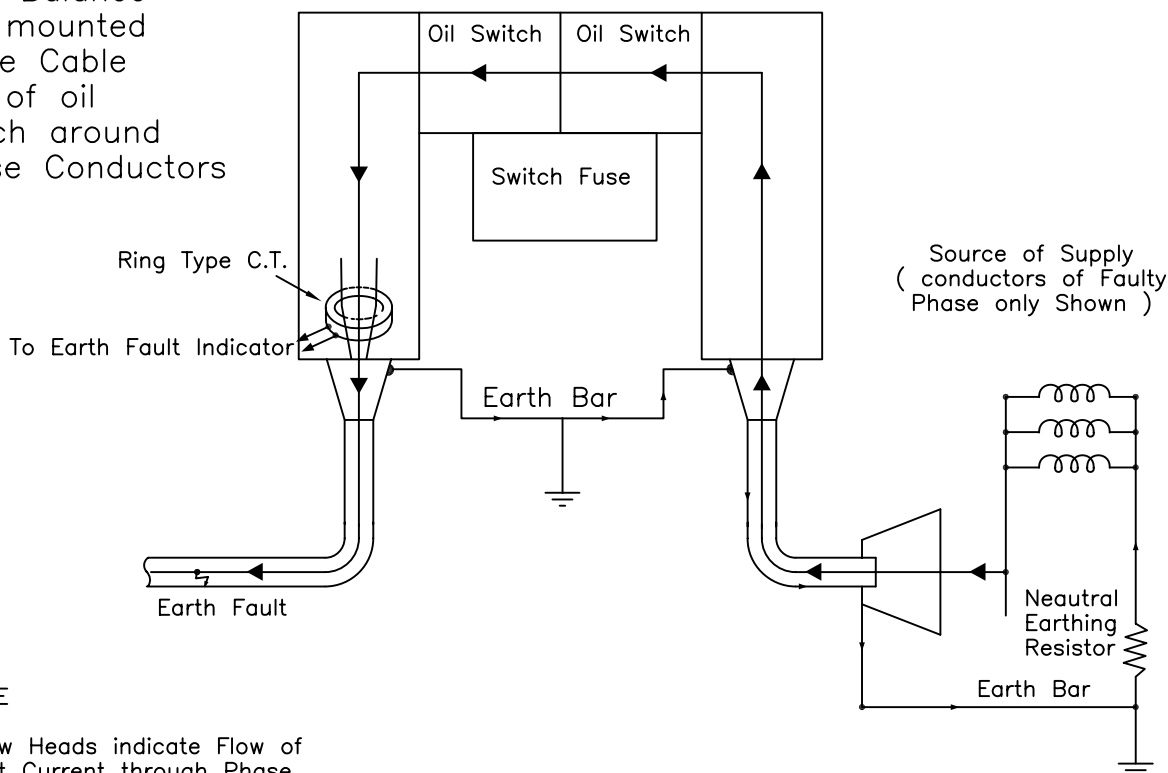

NOTE

Arrow Heads indicate Flow of Fault Current through Phase Conductor and Return path via Cable Sheath to System Neutral

 <b>CEYLON ELECTRICITY BOARD</b>	<b>DISTRIBUTION STANDARDS &amp; SPECIFICATION</b>		SCALE : NOT TO SCALE
	<b>APPLICATION OF EARTH FAULT INDICATORS ON RING MAIN CABLE SYSTEM</b>		DRAWN : LALANI
	DESIGNED BY	APPROVED BY	DATE : March, 1996
			DRG. NO : DS&S/017/2/1996
	<b>DIST. PLANNING BRANCH</b>	Chief Engineer (DS & S)	CHAIRMAN, SPECIFICATION COMMITTEE

**Amendment Slip “General Amendments to CEB Specification”  
Effective from 05-10-2005**

**REVISED TEXT**

---

1. Tender form, Schedule of Prices, Letter of Authorization, Power of Attorney documents shall be signed in Blue Ink. Name of the persons signing shall be clearly indicated and their official stamp has to be put in.
  
2. Bidders shall include with their offer the Type Tests Report/Certificates in accordance with the Standard specified, obtained from an accredited independent test laboratory acceptable to the CEB.

Proof of accreditation by a national/international authority shall also be forwarded with the offer.

Test Reports shall be complete including all the pages as issued by the Testing Authority. Parts of the Test Report shall not be acceptable.

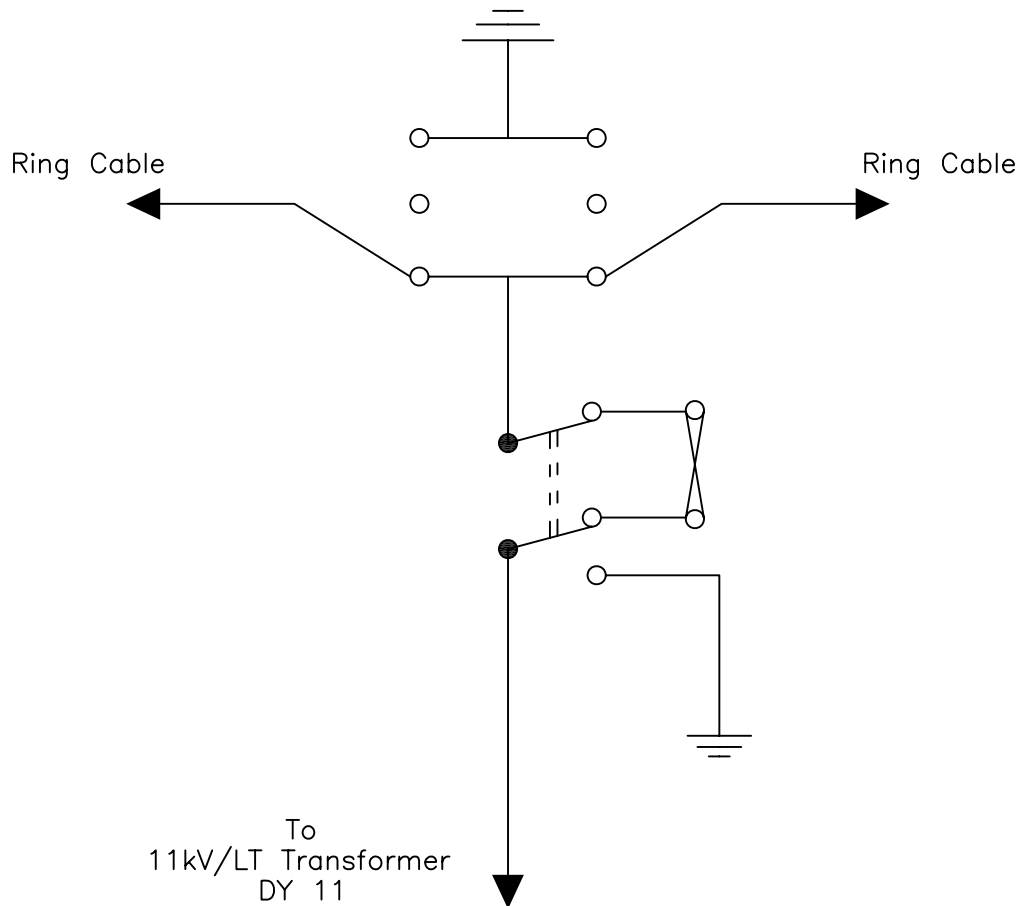

 <p>CEYLON ELECTRICITY BOARD</p>	<b>DISTRIBUTION STANDARDS &amp; SPECIFICATION</b>		SCALE : NOT TO SCALE
	<b>SCHEMATIC DIAGRAM</b>		DRAWN : LALANI
	DESIGNED BY	APPROVED BY	DATE : March, 1996
			DRG. NO : DS&S/017/1/1996
			CAD NO :
<b>DIST. PLANNING BRANCH</b>	Chief Engineer (DS & S)	CHAIRMAN, SPECIFICATION COMMITTEE	